

NOTE:
ALL EXTERIOR STOREFRONT, TRANSOMS AND AND DOORS:
DURATHERM,
FINISH: Ribbon sawn Sapele mahogany

ALL EXTERIOR GLASS:
1" INSULATED VITRO SOLARBAN 90 (2) CLEAR +CLEAR GLASS FILLED
WITH ARGON, U FACTOR= 0.24, SHGC=0.23

DOOR ID	LOCATION		TYPE	DOOR					FRAME		DETAILS			FIRE	HARDWARE SET
	RM #	RM NAME		WIDTH	HEIGHT	THK	MATL	GLZ	W	THK	HEAD	JAMB	SILL		
D001	105	PDR	C	9'-1"	10'-0"	0'-1 3/4"	WD	YES	0'-2"	0'-6 1/4"				Unrated	H2
D002	103	DINING 1	D	3'-0"	9'-10"	0'-1 3/4"	WD	YES	2.00"	0'-6 1/4"				Unrated	H3
D003	103	DINING 1	D	13'-10"	10'-0"	0'-2 1/4"	WD	YES	0'-2"	0'-10 1/4"				Unrated	H2
D004	103	DINING 1	D	13'-10"	10'-0"	0'-2 1/4"	WD	YES	0'-2"	0'-10 1/4"				Unrated	H2
D005	101	ENTRY	A	3'-0"	9'-11 1/2"	0'-1 3/4"	WD	YES	2.00"	0'-6 1/4"				Unrated	H1
D006	101	ENTRY	A	3'-0"	9'-11 1/2"	0'-1 3/4"	WD	NO	2.00"	0'-6 1/4"				Unrated	H1
D007	114	DINING 2	D	14'-1"	7'-10"	0'-1 3/4"	WD	YES	0'-2"	0'-10"				Unrated	H2
D008	114	DINING 2	D	14'-1"	7'-10"	0'-1 3/4"	WD	YES	0'-2"	0'-10"				Unrated	H2
D101	105	PDR	I	2'-10"	11'-6"	0'-2"	WD	NO	0'-0"	0'-1 7/8"				Unrated	H7
D102	105	PDR	J	10'-7 1/2"	10'-0"	0'-0 1/2"	GL	N/A	0'-0 1/4"	0'-0 1/2"				Unrated	H5
D103	102	WINE ROOM	K	2'-10"	8'-0"	0'-0 1/2"	GL	N/A	0'-0 1/4"	0'-0 1/2"				Unrated	H6
D104	110	ADA WC	E	3'-0"	7'-10"	0'-1 3/4"	WD	YES	0'-0 3/4"	0'-4"				Unrated	H8
D105	111	WC	E	3'-0"	7'-10"	0'-1 3/4"	WD	YES	0'-0 3/4"	0'-4"				Unrated	H8
D106	112	WC	E	3'-0"	7'-10"	0'-1 3/4"	WD	YES	0'-0 3/4"	0'-4"				Unrated	H8
D107	113	ADA WC	E	3'-0"	7'-10"	0'-1 3/4"	WD	YES	0'-0 3/4"	0'-4"				Unrated	H8
D108.1	117	KITCHEN	H	3'-0"	6'-8"	0'-1 3/4"	MTL	YES	0'-0 3/4"	0'-4"				Unrated	H9
D108.2	117	KITCHEN	H	3'-0"	6'-8"	0'-1 3/4"	MTL	YES	0'-0 3/4"	0'-4"				Unrated	H9
D109	117	KITCHEN	F	3'-0"	7'-0"	0'-1 3/4"	MTL	NO	0'-0 3/4"	0'-4"				2 hour	H4
D201	205	MECH RM	F	3'-0"	6'-8"	0'-1 3/4"	MT	NO	2.00"	0'-4"				Unrated	H12
D202.1	201	KITCHEN	F	2'-6"	6'-8"	0'-1 3/4"	MTL	NO	2.00"	0'-4"				Unrated	H13
D202.2	202	OFFICE	F	2'-6"	6'-8"	0'-1 3/4"	MTL	NO	2.00"	0'-4"				Unrated	H10
D203	203	WC	F	2'-6"	6'-8"	0'-1 3/4"	MTL	NO	2.00"	0'-4"				Unrated	H11
D204	205	MECH RM	G	3'-0"	6'-8"	0'-1 3/4"	MTL	NO	2.00"	0'-4"				1 hour	H12
D205	201	KITCHEN	F	4'-6"	7'-0"	0'-1 3/4"	MTL	NO	0'-2"	0'-4"				Unrated	H12

City of Houston 167, ac



TES

18076069

REVIEWED FOR COMPLIANCE

Performance of this review does not relieve the applicant from full responsibility to comply with all applicable codes, ordinances and regulations 10/29/18

DOOR TYPES

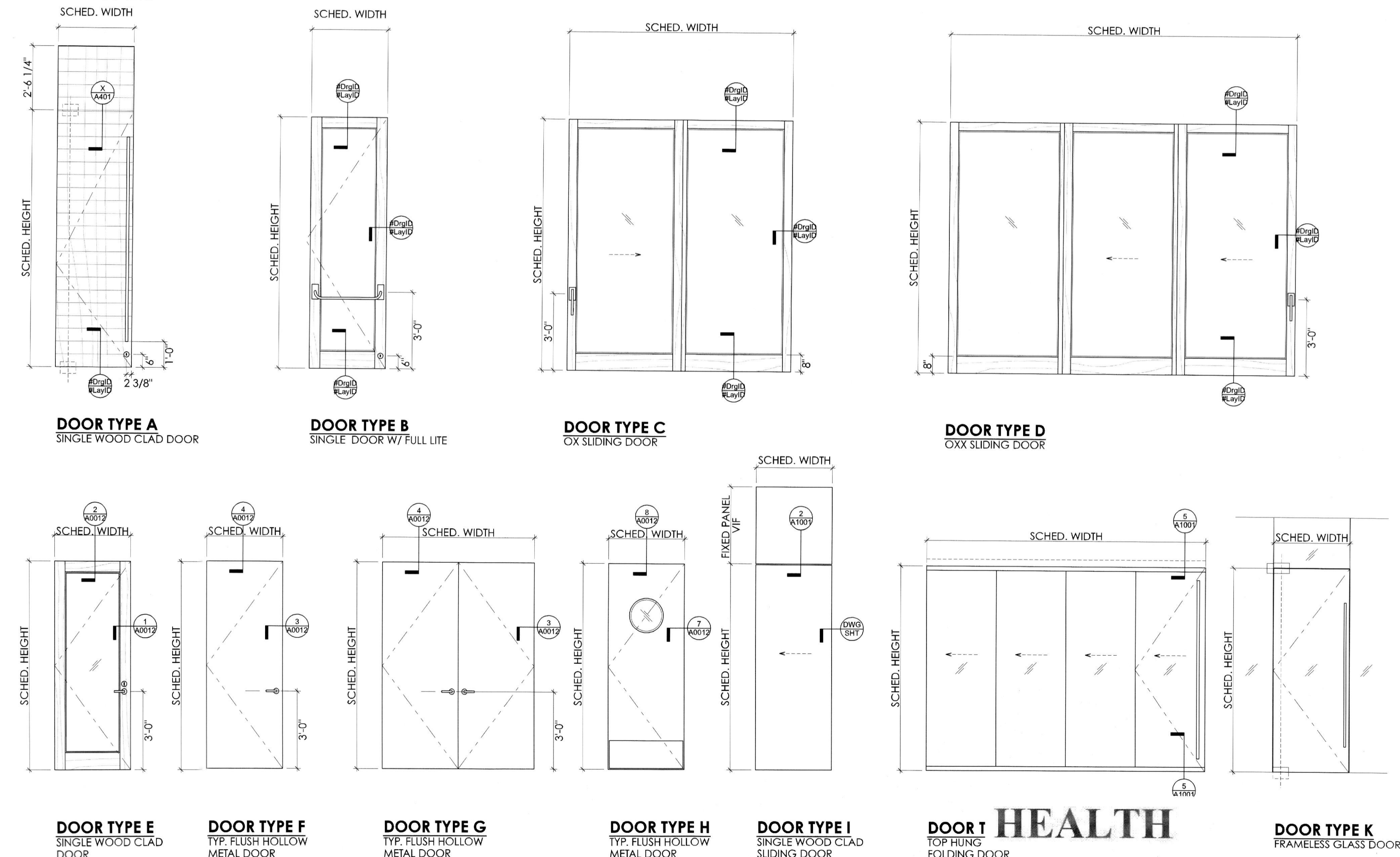

FRAME TYPES

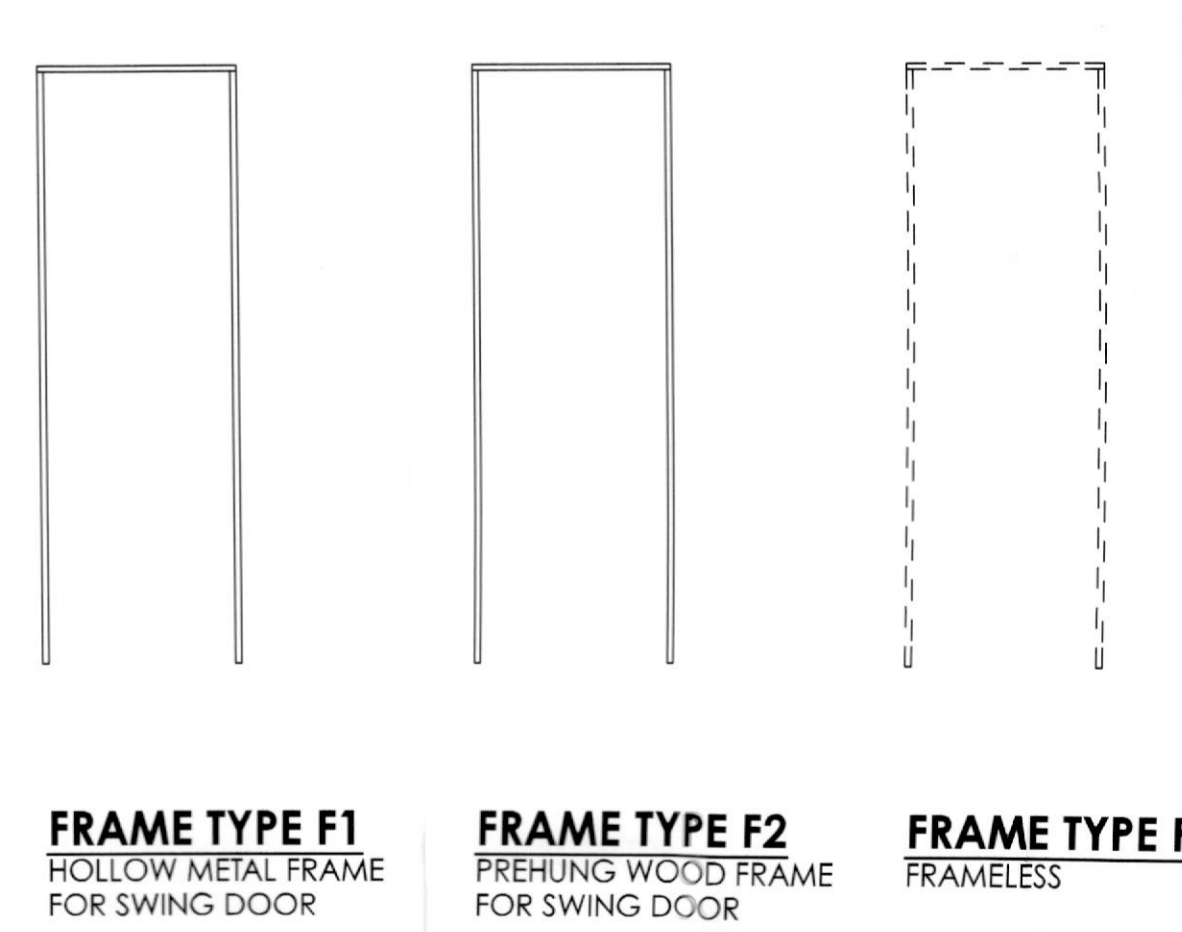

<p>ARCHITECT HapstakDemetriou + ARCHITECTURE DESIGN 2715 M STREET NW, 4th Floor WASHINGTON, DC 20007 202.333.9038 www.hd-ad.com info@hd-ad.com</p>	<p>CLIENT Axanader Smith (40) 241-1224 smith11@gmail.com</p> <p>STRUCTURAL ENGINEER E1 Structural Engineers 380 Pender Dr. Suite 175 Fairfax, VA 22030</p>	<p>MEP ENGINEER JB. Wyble and Associates, P.A. 7950 Norfolk Ave., Bethesda, MD 301-654-1410</p> <p>FOOD SERVICE CONSULTANT JIA Corp 1331 US Highway 19N, Clearwater, FL 33764 77-470-7862</p>	<p>OUZO BAY HOUSTON 4444 WESTHEIMER RD, HOUSTON, TX 77027, SUITE 130</p> <p>PROJECT NO. 17054</p>		<table border="1"> <tr><th>REV</th><th>DATE</th><th>ISSUED FOR</th></tr> <tr><td>—</td><td>5/16/18</td><td>PROGRESS SET</td></tr> <tr><td>—</td><td>6/20/18</td><td>PERMIT SET</td></tr> <tr><td>①</td><td>8/30/18</td><td>PERMIT COMMENT</td></tr> </table>	REV	DATE	ISSUED FOR	—	5/16/18	PROGRESS SET	—	6/20/18	PERMIT SET	①	8/30/18	PERMIT COMMENT	<table border="1"> <tr><th>REV</th><th>DATE</th><th>ISSUED FOR</th></tr> <tr><td>—</td><td>—</td><td>—</td></tr> <tr><td>—</td><td>—</td><td>—</td></tr> <tr><td>—</td><td>—</td><td>—</td></tr> </table>	REV	DATE	ISSUED FOR	—	—	—	—	—	—	—	—	—	<p>DOOR AND STOREFRONT SCHEDULE</p> <p>A0011</p> <p>PRINTED: 9/17/18 © HapstakDemetriou+, pllc 2018</p>
REV	DATE	ISSUED FOR																													
—	5/16/18	PROGRESS SET																													
—	6/20/18	PERMIT SET																													
①	8/30/18	PERMIT COMMENT																													
REV	DATE	ISSUED FOR																													
—	—	—																													
—	—	—																													
—	—	—																													

I CERTIFY THAT THESE DOCUMENTS WERE PREPARED OR APPROVED BY ME, AND THAT I AM A DULY LICENSED ARCHITECT UNDER THE LAWS OF TEXAS LICENSE NO. 26750 EXPIRATION DATE: 7/31/2019