

**FLOOR PLAN - LIGHTING**  
SCALE: 1/4"=1'-0"

**DRAWING NOTES**

- ① ONE SWITCH CONTROLS ONE TRACK HEAD. COORDINATE LOCATION WITH OWNER.

**GENERAL NOTES**

- 1. ALL LIGHTING FIXTURES ARE TYPE 'A' UNLESS OTHERWISE NOTED.
- 2. CONNECT EXIT SIGNS, EMERGENCY BATTERY UNITS AND NIGHT LIGHTS (NL) TO THE UNSWITCHED PORTION OF THE LIGHTING CIRCUIT SERVING THAT RESPECTIVE AREA.

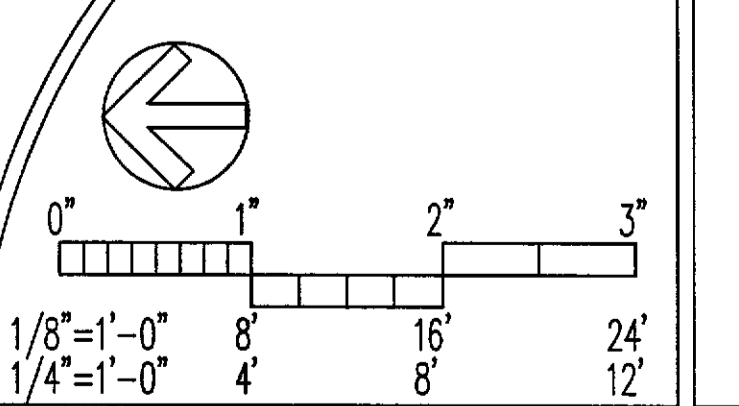

**FLOOR PLAN - LIGHTING**

REVISIONS		DATE	DESCRIPTION

REVISIONS	
DATE	
BY	
CHECKED BY	

DRIVING NO.	
SHEET	3 OF 5
DATE	1/4/01
BY	NJB
CHECKED BY	TEJ
SCALE	1-1000

RENOVATIONS TO:  
**RMS LIFELINE**  
 DETROIT

InSync ARCHITECTURAL DESIGNS, INC.  
 3837 JARRETTVILLE PIKE  
 JARRETTVILLE, MARYLAND 21084  
 PHONE 410-557-9300  
 FAX 410-557-2583

**Don Penn Consulting Engineers**  
 3860 HIGHWAY 3860, SUITE 101  
 GRAPEVINE, TEXAS 76051  
 817-402-2888 FAX 817-201-0411

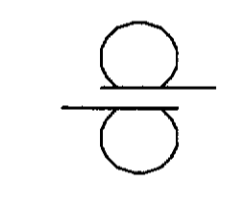

1  
 2  
 3  
 4  
 5  
 6  
 7  
 8  
 9